

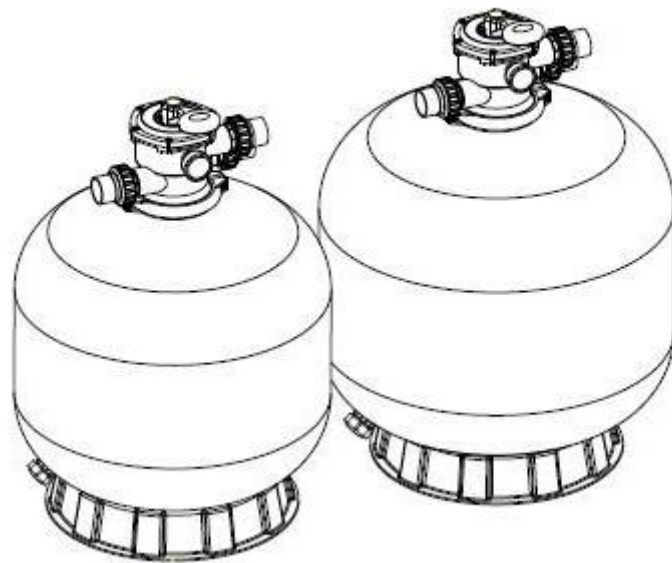

SAND FILTERS

Models: SF500, SF650, SF700 & SF800



FUNCTION

The filter uses special filter media to remove dirt particles from pool water. The filter media is loaded into the filter tank and functions as a permanent dirt removing media. When the multiport valve is in the FILTER position, the pool water which contains suspended dirt particles, is pumped through your piping system and is automatically directed by the patented filter multiport valve to the top of the filter tank. As the pool water is pumped through the filter, dirt particles are trapped by the media bed, and filtered out. The cleaned pool water is returned from the bottom of the filter tank, through the multiport valve and back to the pool through the piping system. This entire sequence is continuous and automatic. It provides for total recirculation of pool water through your filter and piping system.

After a period of time, the accumulated dirt in the filter causes a resistance to flow, and the flow diminishes. This means it is time to clean your filter. With the multiport valve in the BACKWASH position, the water flow is automatically reversed through the filter so that it is directed to the bottom of the tank, up through the media, flushing the previously trapped dirt and debris out the waste line. Once the filter is back-washed of dirt, set the multiport valve to the RINSE position and run pump for about 15 to 30 seconds, and then set the multiport valve in the FILTER position, to resume normal filtering.

NOTE: Turn pump OFF before changing the multiport valve position.

INSTALLATION

Only simple tools plus pipe sealant for plastic adapters are required to install and service the filter.

1. The filter should be placed on a level concrete slab, very firm ground, or equivalent. The filter should be placed in the right position so that the piping connections, multiport valve are convenient and accessible for operation and service. Position the tank with MPV in place to determine final position for piping.
2. Filter media is loaded through the top opening of the filter.
 - a. (For 500/650) Loosen the flange clamp and remove filter multiport valve (if previously installed).
 - a. (For 700/800) Loosen the flange Nuts and remove filter multiport valve (if previously installed).
 - b. Cap internal pipe with plastic cap to prevent filter media from entering it.
 - c. We recommend filling the tank approximately 1/2 way with water to provide a cushion effect when the filter media is poured in. This helps protect the under-drain laterals from excessive shock.
 - d. Carefully pour in correct amount and grade of filter media. (Be sure centre pipe remains centred in opening.) Media surface should be levelled and should come to about the middle of the filter tank. Remove plastic cap from internal pipe.
3. Assemble filter multiport valve onto the filter tank.
 - a. Insert multiport valve (with O'ring or casket in place) onto the tank neck, taking care that the centre pipe slips into the hole in the bottom of the valve.
 - b. (For 500/650) Place clamp around valve flange and tank flange and tighten just enough so that the valve may be rotated on tank for final positioning.
 - b. (For 700/800) Place nuts on all studs around valve flange and tighten just enough so that the valve casket seals (Do not over tighten).
 - c. Carefully screw pressure gauge (with tread tape) into tapped hole in valve body. Do not over-tighten.
 - d. Connect pump to multiport valve opening marked PUMP. After connections are made, recheck to ensure nuts or clamp band on multiport valve flange are tight.
4. Make the return to pool pipe connection to multiport valve opening marked RETURN and complete other necessary plumbing connections, suction lines to pump, waste, etc.
5. Make electrical connections to pump per pump instructions.
6. To prevent water leakage, make sure all pipe connections are tight.

MAIN DIMENSION

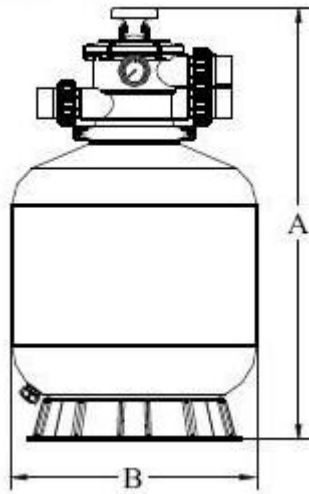

DIMENSION TABLE

MODEL	Height mm A	Diameter mm B	Valve port size mm/inch	Sand Kg / bags	Zeolite Kg / bags	Coarse Glass kg / bags	Fine Glass kg / bags
SF500	845	535	40 / 1.5	80 / 4	60 / 4	25 / 2	40 / 3
SF650	950	635	40 / 1.5	140 / 7	105 / 7	45 / 3	60 / 4
SF700	1020	710	50 / 2.0	220 / 11	165 / 11	60 / 4	105 / 7
SF800	1200	800	50 / 2.0	260 / 13	195 / 13	75 / 5	120 / 8

INSTALL/START-UP OF FILTER

1. Make sure the correct amount of filter media is located in the tank and all connections have been connected and secured.
 2. Depress multiport valve handle and rotate to BACKWASH position. (To prevent damage to multiport valve seal, always depress handle before turning.)
 3. Prime and start pump according to pump instructions (be sure all suction and return lines are open), allowing the filter tank to fill with water. Once water is flowing out of the waste line, run the pump for at least 1 minute. The initial back-washing of the filter is recommended to remove any impurities or fine particles in the filter media
 4. Turn pump off and set valve to RINSE position. Start pump and operate until water in sight glass is clear, about 30 seconds. Turn pump off and set valve to FILTER position and restart pump. The filter is now operating in the normal filter mode, filtering dirt particles from the pool water.
 5. Adjust pool suction and return valves to achieve desired flow. Check system and filter for water leaks and tighten connections, bolts, nuts, as required.
 6. Note the initial pressure gauge reading when the filter is clean. (It will vary from pool to pool depending upon the pump and general piping system.) As the filter removes dirt and impurities from the pool water, the accumulation of dirt in the filter will cause the pressure to rise and diminish the water flow. When the pressure gauge reading is 50kpa, higher than the initial "clean" pressure you noted, it is time to backwash the filter (see BACKWASH under filter and multiport valve functions).
- NOTE: During initial clean-up of the pool water it may be necessary to backwash frequently due to the unusually heavy initial dirt load in the water.

REPLACEMENT PARTS OF FILTER SF500 & SF650

(Diagrams are for illustrative purposes and may vary slightly on actual filter)

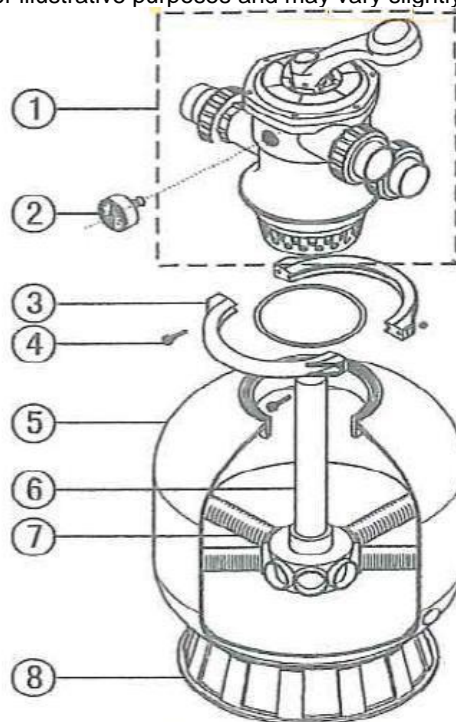

Item	Part number	Description
1	MPVB4/MPVB5	Multiport Valve (see breakdown)
2	PGSL, or PGSC	S/Steel Oil filled Pressure gauge (Mounting Centre or Lower)
3	SF001 SF002	Flange Clamp SF550/650 Hinge Clamp SF500/650
4	SF004 SF305	Screw with Nut SF500/650 Nut For Flange SF700/800
5	SF501 SF651 SF701 SF801	SF500 Tank SF650 Tank SF700 Tank SF800 Tank
6	SF006 SF007 SF307 SF308 SF009 SF010 SF309 SF310	Lateral Assembly (SF500) Lateral Assembly (SF650) Lateral Assembly (SF700) Lateral Assembly (SF800) Centre Pipe (SF500) Centre Pipe (SF650) Centre Pipe (SF700) Centre Pipe (SF800)
7	SF012 SF012 SF312 SF312	Lateral (SF500) Lateral (SF650) Lateral (SF700) Lateral (SF800)
8	SF015 SF015 SF315 SF315	Filter Base (SF500) Filter Base (SF650) Filter Base (SF700) Filter Base (SF800)

REPLACEMENT PARTS OF MULTIPOINT VALVE SF500 & SF650

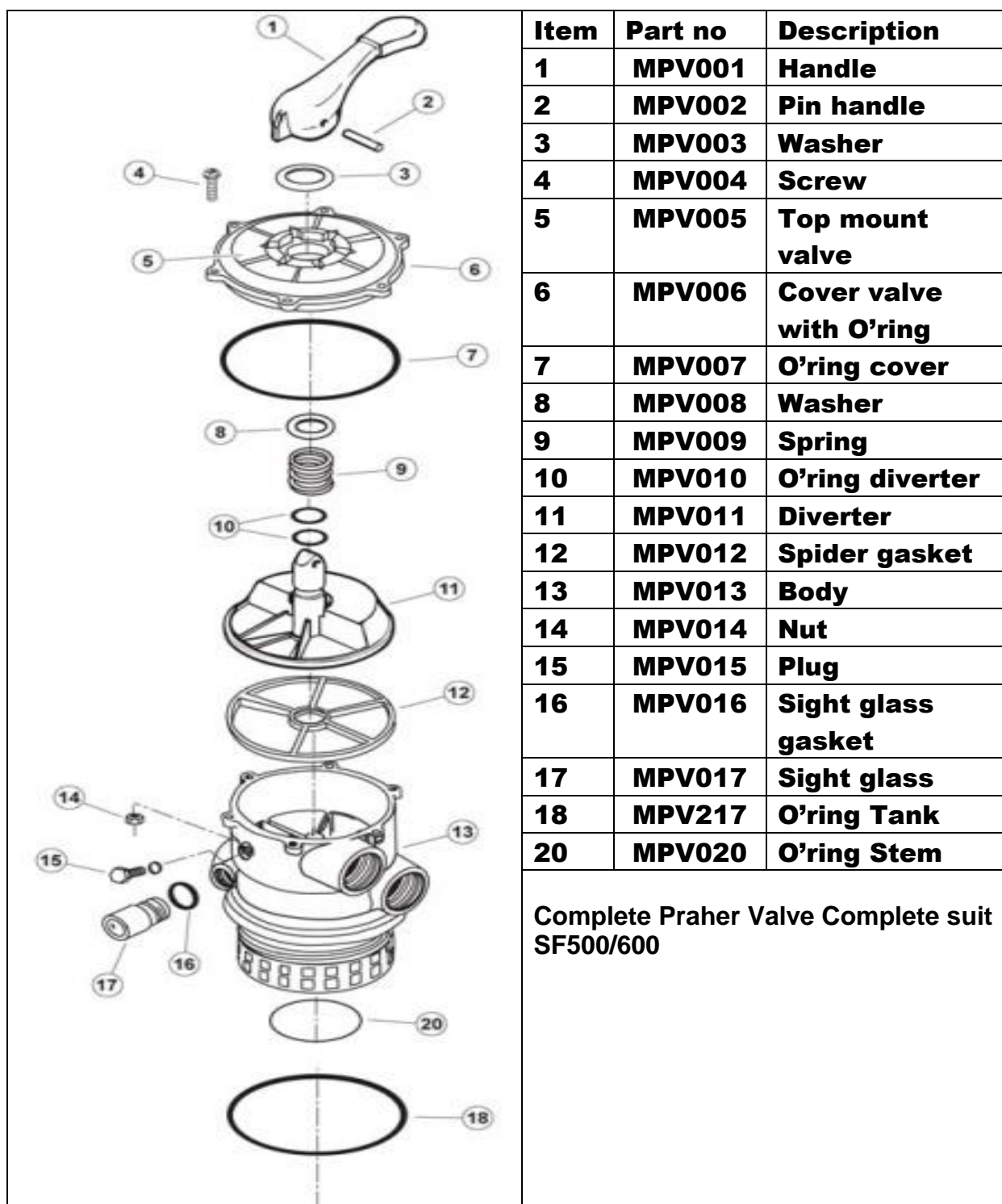

Suits SF700 and SF800

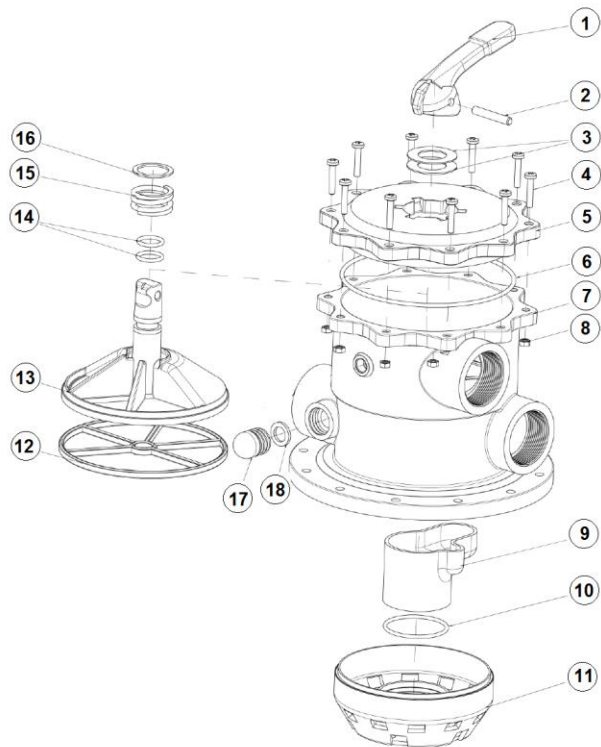

Complete multiport valve item code: MPVB5

1	MPV001	Handle
2	MPV002	Pin Handle
3	MPV003	Washer for handle
4	MPV104	Bolt
5	MPV105	2" Top Mount Lid
6	MPV106	O'ring Lid
7	MPV107	Body Black
8	MPV108	Nut for Bolt
9	MPV109	Spigot Valve
10	MPV110	O'ring Stand pipe
11	MPV111	Diffuser
12	MPV112	Spider Gasket
13	MPV113	Rotor
14	MPV114	O'ring x 2
15	MPV115	Spring
16	MPV116	Washer Spring
17	MPV117	Sight Glass
18	MPV118	Gasket Sight Glass
19	MPV119	Union Complete
20	MPV120	Union O'ring

Complete Praher Multiport Valve MPVB5 Suits SF 700 & 800

FUNCTIONS OF VALVE POSITIONS

(Diagrams are for illustrative purposes and may vary slightly on actual valve))

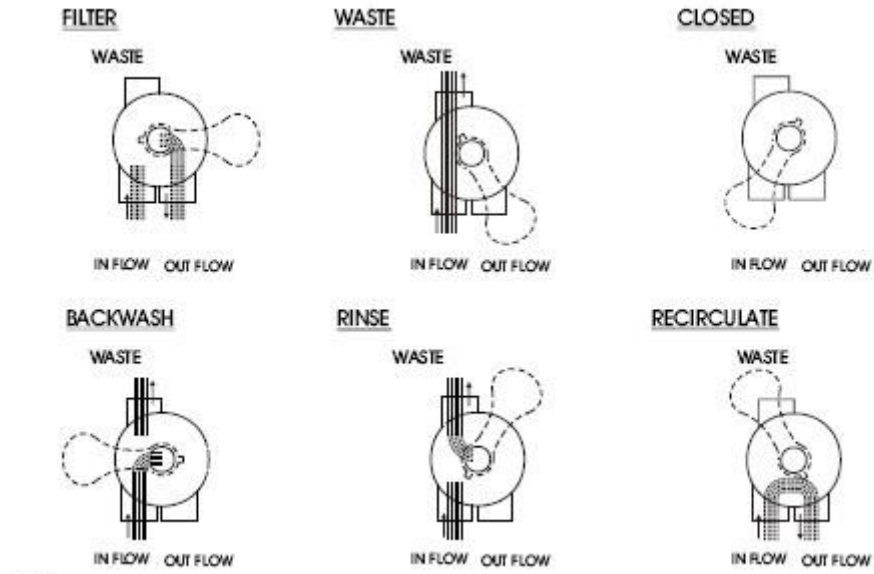

VALVE POSITION	FUNCTION
FILTER	Normal filtration and vacuuming
FILTER BACKWASH	Cleaning filter by reversing the flow
RINSE	Used after backwash to flush dirt from valve
WASTE	By passes filter, used for vacuuming to waste or lowering water level
RECIRCULATE	By passes filter for circulating water to pool
CLOSED	Shuts off all flow to filter or pool

GENERAL

2. **SERVICING VALVE** (Stop pump, close gate valve in suction & discharge before proceeding):

a. Set handle in filter position. b. Remove cover screws. c. Lift cover and key assembly out.

TO ASSEMBLE:

1. Place valve key so that wedge opening is at TOP port (handle in filter position). Flat edge of cover screw lug should align with flat edge of body screw lug.

2. Position cover O'ring.

3. Secure assembly to body with cover screws. Tighten cover screws evenly and alternately. Do not over-tighten.

WARNING

- ▲ THIS FILTER OPERATES UNDER HIGH PRESSURE. WHEN ANY PART OF THE CIRCULATING SYSTEM (e.g. CLAMP, PUMP, FILTER, VALVES, ETC.) IS SERVICED, AIR CAN ENTER THE SYSTEM AND BECOME PRESSURISED. PRESSURISED AIR CAN CAUSE THE LID OR VALVE TO BE BLOWN OFF WHICH CAN RESULT IN SEVERE INJURY, DEATH, OR PROPERTY DAMAGE

- ▲ TURN PUMP OFF BEFORE CHANGING VALVE POSITION.

- ▲ TO PREVENT DAMAGE TO THE PUMP AND FOR PROPER OPERATION OF THE SYSTEM, CLEAN PUMP STRAINER AND SKIMMER BASKETS REGULARLY

- ▲ DO NOT UNSCREW SCREWS OF FLANGE CLAMP WHILE PUMP IS RUNNING.

WARRANTY:

- ▲ The filter tank is warranted against manufacturer's defects for a period of 10 years.
- ▲ Internals (laterals and assembly, centre pipe) are warranted against manufacturer's defects for a period of 12 months.
- ▲ The pressure gauge is warranted against manufacturer's defects for a period of 12 months.
The Praher multiport valve is warranted against manufacturer's defects for a period of 2 years.



is brought to you by **POOL PRO PRODUCTS**

Address	10-12 Cairns Street Loganholme Queensland 4129 Australia
Phone:	1800 14 37 88
Fax:	1800 77 88 20
Web:	www.poolpro.com.au

Warranty

Neptune Sand Filter by Pool Pro

Pool Pro warrants the Neptune Sand Filters only for the original purchaser of the Sand Filter. The warranty is non-transferable. Pool Pro warrants the Sand Filter to be free of manufacturer defects in materials and workmanship, periods outlined below:
Filter tank for a total period of ten (10) years, from the date of purchase.

- "SF" range Praher multiport valve for a total period of two (2) years, from the date of purchase.
- "Eco" range multiport valve for a total period of one (1) year, from the date of purchase.
- Internals (lateral assembly & centre pipe) for a total period of one (1) year, from the date of purchase.
- Pressure gauge for a total period of one (1) year, from the date of purchase.

Warranty does not cover damage caused by negligence, improper use, improper maintenance, lack of care when using the product, incorrect installation, nor does it cover aggressive climate or location. Repairs under warranty can only be performed by an authorised Pool Pro repair agent. Proof of purchase must be shown to validate warranty. Warranty is for domestic applications only. Commercial applications of this product and components are warranted for a period of twelve (12) months from date of purchase, unless otherwise advised in writing by Pool Pro. Pool Pro will not be responsible for costs, losses or damages incurred whether directly or indirectly arising from Pool Pro products. Any action taken upon the product (such as disassembly) by any party not authorised to perform warranty repair on the product will void the warranty. Pool Pro goods are warranted without exclusion to your rights under the Australian Consumer Law. In the unlikely event that you have a warrantable problem with any Pool Pro product, simply contact the place of purchase or contact Pool Pro direct by email at: service@poolpro.com.au



This warranty form and a copy of your original purchase receipt must be lodged within 30 days from date of purchase or any warranty claim may be voided. Post the lower half to:
The POPS Group Pty Ltd (Pool Pro Products)
PO Box 4183
Loganholme DC QLD 4129
Australia

Warranty Registration Form



by



Thank you for purchasing a Pool Pro product!

All fields **MUST** be completed in **BLOCK CAPITALS** and **BLACK INK** and be **LEGIBLE**.

Failure to complete all sections may void any warranty claim.

Please attach a copy of your original purchase receipt when lodging this form.

Item purchased:

- Pump
 Sand Filter
 Pool Cleaner
 Cartridge Filter
 Chlorinator
 Other *If other please describe:* _____

Item Make	
Item Model	
Serial Number (if applicable)	
Purchased From (store name)	
Purchase Date	
Price Paid	
Your Name (first & last names)	
Your Address (incl. suburb & postcode)	
Daytime Telephone Number	
Email Address	

- Tick if you would like to receive updates of our new products as they become available.